

Product Installation guide

IP66

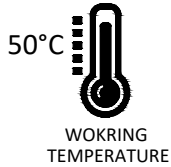

MAKE SURE THE POWER IS OFF DURING INSTALLATION



220-240V~
50/60 Hz

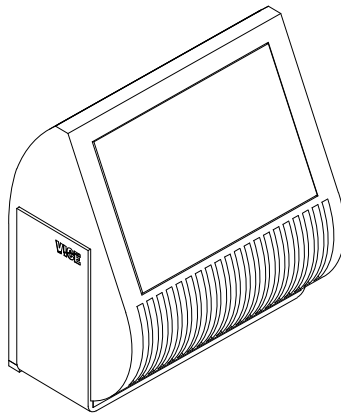
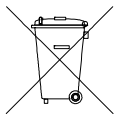

INSTALLATION INSTRUCTIONS

DISCLAIMER

Please read all instructions before beginning installation:

1. Turn off electrical power before starting the installation of the light fixture.
2. The feeding voltage must not exceed the specified fixture voltage.
3. This product must be installed by an eligible electrician.
4. Make sure the luminaire is mounted to a secure structure. Mounting the fixture in inappropriate way could lead to serious injury.
5. This luminaire is class 1, it must be earthed in a reliable way.
6. The light source of this luminaire shall only be replaced by the manufacturer, his service agent or a similar qualified person.
7. Wear gloves and safety glasses at all times when removing the luminaire from carton, installing, servicing or performing maintenance
8. Do not install damaged product! This luminaire is properly packed to avoid being damaged during transit. Inspect to confirm before installation. Any damaged or broken part during or after assembly should be replaced.
9. Unauthorized repairs or modifications will void warranty.

Isometric View:

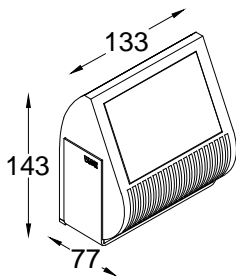

Uno

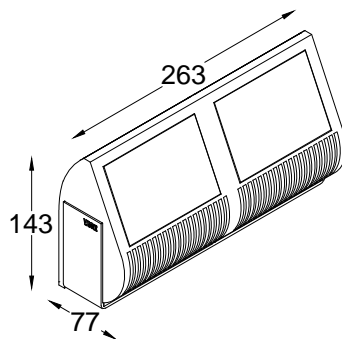

DUO

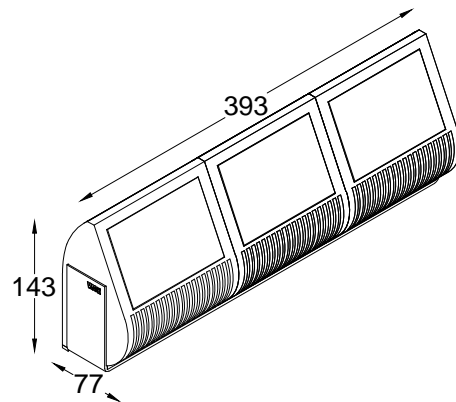

TRIO

Dimensions in mm

Product Installation guide

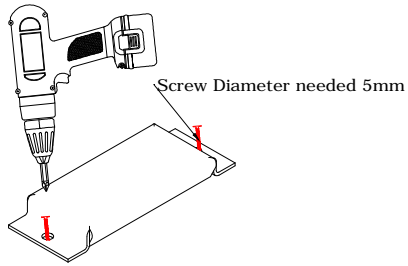

1 Fix the mounting bracket on the surface

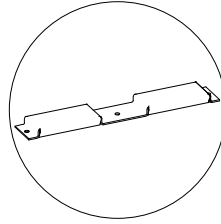

Bracket for Duo

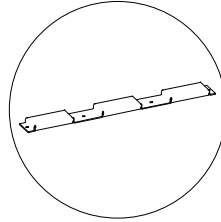

Bracket for Trio

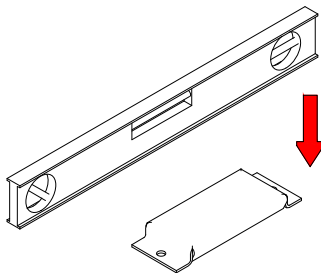

2 Align the bracket with the Surface

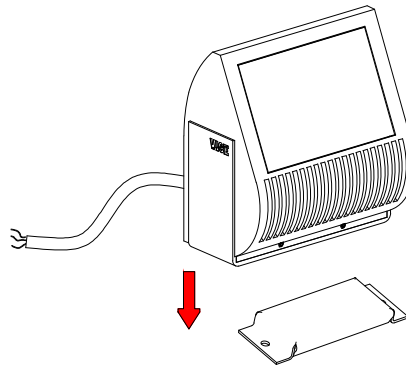

3 Slide the Fixture toward the bracket

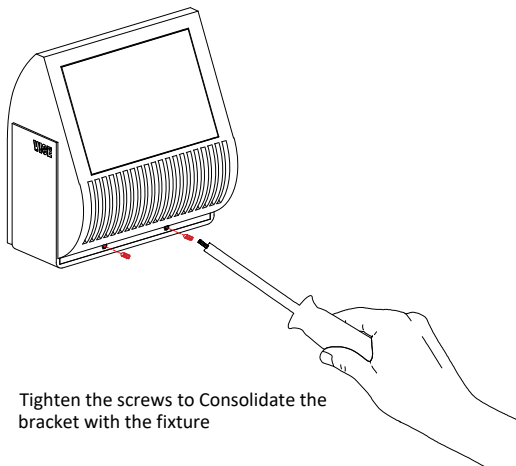

4 Tighten the screws to Consolidate the bracket with the fixture

Electrical Wiring

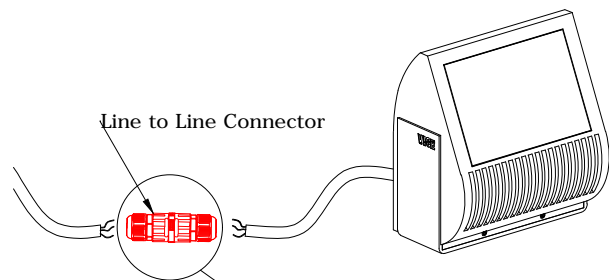

3Poles for Non dimmable



5Poles for DALI and 1-10V dimmable